

1,207,464.

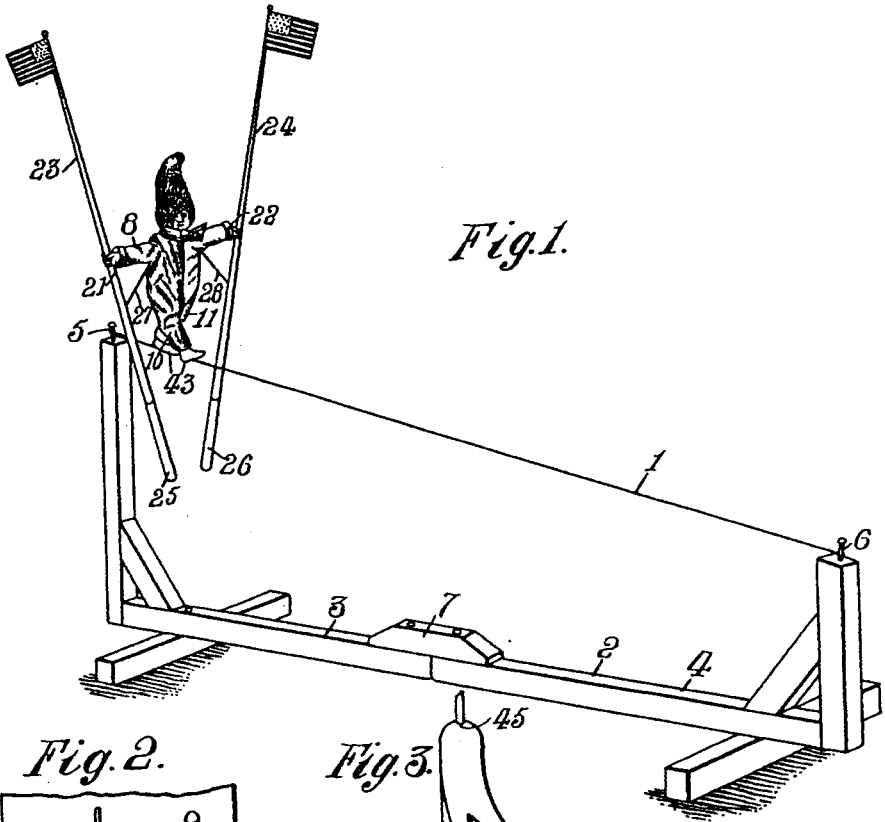
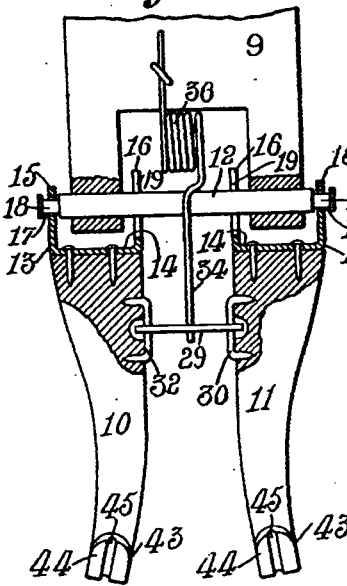

Fig. 1.

Fig. 2.



WITNESSES
 J. A. Propoy
 A. Medley

Fig. 3.

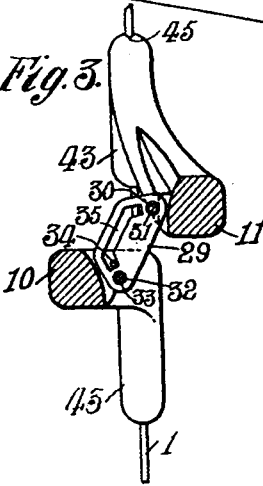

Fig. 5.

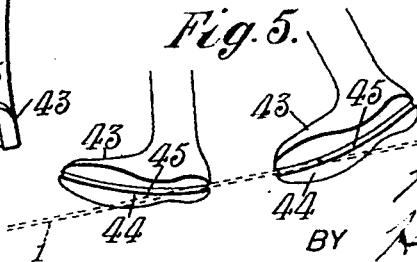
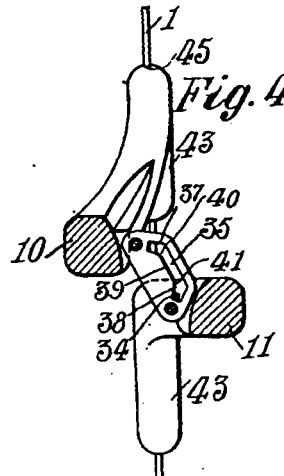

Fig. 4.



INVENTOR.
 H. Allison
 BY Horatio Harting
 ATTORNEY

1,207,464.

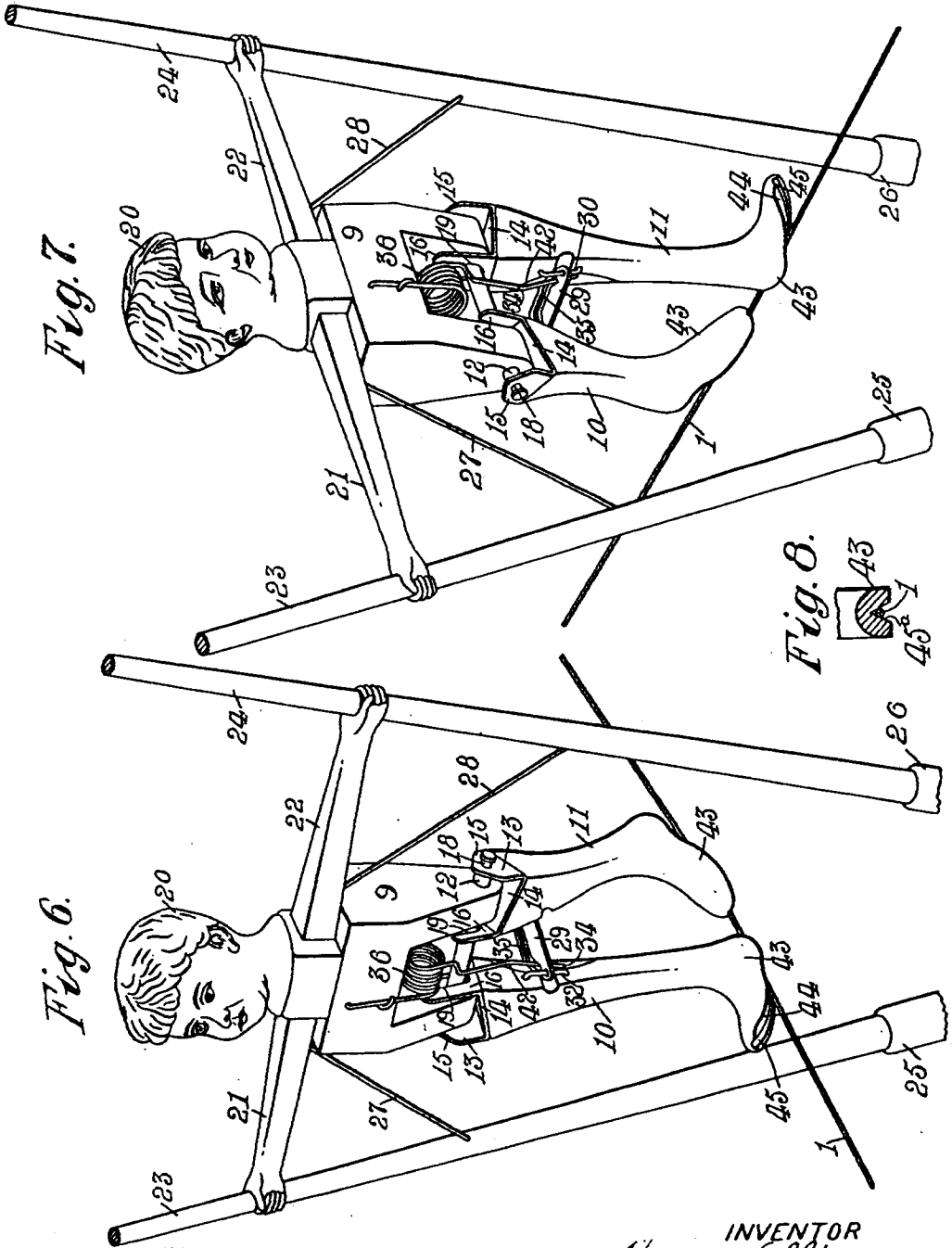

Fig. 6.

Fig. 7.

WITNESSES
J. A. Proffery
[Signature]

INVENTOR
Harvey Allison
BY Horatio Whiting
ATTORNEY

UNITED STATES PATENT OFFICE.

HARVEY ALLISON, OF WEST ORANGE, NEW JERSEY.

TOY.

1,207,464.

Specification of Letters Patent.

Patented Dec. 5, 1916.

Application filed March 18, 1914. Serial No. 825,444.

To all whom it may concern:

Be it known that I, HARVEY ALLISON, a citizen of the United States, and a resident of West Orange, in the county of Essex and State of New Jersey, have invented certain new and useful Improvements in Toys, of which the following is a specification.

This invention relates to a new and improved toy and more particularly to a toy adapted to automatically walk on a narrow path such as a stretched wire.

The object of this invention is to produce a toy which will automatically walk step by step along a narrow path such as a stretched or tight rope without the aid of winding a spring or supplementary power and merely by the force of gravity itself, due to the slight inclination of the rope or the wire on which the toy is placed.

Considering broadly the more important points of the device, it consists of a manikin arranged with its legs movable so that they will alternately advance one beyond the other, clearing the leg in position on the path and thereby giving the effect of walking along the path. The device is weighted so as to bring the center of gravity quite low and in fact below the path, so that the toy is in balanced poise on the wire and not tending to swing off to one side or the other. The whole effect is produced by the force of gravity acting along a line slightly in advance of the point of support of the manikin on the path. The point or points of support, which consist of the surface of the manikin's feet in contact with the tight rope or wire forming the path, advance step by step to keep pace with the advancing movement of the center of gravity. These and further details will be more fully described hereinafter and particularly pointed out in the claims.

Reference may be had to the accompanying drawing in which like reference characters denote corresponding parts and in which—

Figure 1 is a perspective view showing the manikin in position on a tightened wire ready to start in his walk along the same. Fig. 2 is a fragmental detail view showing the method of attaching the legs to the body portion of the manikin with parts in section to show details thereof. Figs. 3 and 4 are horizontal sectional views showing the relation of the legs to each other. In Fig.

3 one foot is in advance of the other and in Fig. 4 the opposite foot is in advance. These figures also illustrate the means for shifting one leg past the other when advancing the rearmost leg to a position in front of the other leg. Fig. 5 is a detailed perspective view bringing out the idea that the bottoms of the feet of the manikin form in effect a continuous rolling surface, wheel-like in effect. Fig. 6 is a detail perspective view showing the manikin with his clothes removed to disclose the working of the mechanism and illustrating the same with the right foot forward in the act of walking. Fig. 7 is a view similar to Fig. 6, taken from the opposite side showing the left foot forward in the act of walking. Fig. 8 is a detail section showing a modified form of V groove of the soles of the feet of the manikin to engage the tightened wire or cord.

Referring more particularly to the separate parts of this invention as embodied in the form shown in the drawings, 1 indicates a path shown as a tightened rope, cord or wire, of any suitable form and material and tightened in any suitable way as by means of a framework 2. While the framework 2 is illustrated as one means of tightening the wire 1, any other suitable means may be used, as by stretching the same from the hand to a door knob or the like. As illustrated, however, the framework 2 is made of two sections 3 and 4 to which the opposite ends of the wire 1 are attached as at 5 and 6. Sections 3 and 4 are adjustably connected as by means of a link 7 which is pivotally connected to the sections 3 and 4, so that they may be moved relatively to each other after attaching the wire 1 and thus stretch the wire 1 to a tautened condition. The support of the wire 1 may be of any suitable character, so that it will, however, have an inclination such as that illustrated in Fig. 1. The manikin 8 is placed with his feet supported on the path 1, so that both of his feet rest thereon, whereby when the manikin 8 is given a slight forward inclination, the pull of gravity on the center of gravity will cause the manikin to walk step by step down the path 1. To accomplish this, the manikin is formed in a peculiar way and includes a body portion 9 to which a pair of legs 10 and 11, indicating the right and left legs respectively, are secured.

In order that the legs may clear each other in passing by each other so as to alternate their position of advancement, they are secured in a peculiar way to the body portion 9. For this purpose, the body portion 9 has mounted therein a pivot shaft 12. Each leg has a bearing piece 13 by means of which it is attached to the pivot shaft 12. Each bearing piece is of a peculiar form in order to permit of the peculiar motion of each leg. By reference to Figs. 2, 6 and 7, it will be seen that the bearing piece 13 is of a U shaped form secured at the web 14 to the leg and having flanges 15 and 16 extending upwardly therefrom to engagement with the pivot shaft 12. It will be noted that the flange 15 is provided with an opening 17 whereby it is somewhat loosely supported by and secured on a reduced portion 18 of the pivot shaft 12. It will be further noted that the flange 16 in place of having an opening 17 is provided with a slot 19 which engages with the shaft 12. This permits not only a back and forth swinging movement about the shaft 12 as a pivot in the direction of travel of the manikin, but also permits an outward and inward swinging movement to enable the leg to clear the path or wire 1 and pass around the leg in position on the path to a point in advance thereof where it again moves inward to a position in engagement with the path. That is to say, the connection of each leg to the body portion 9 is in the nature of a universal joint permitting a peculiar gyratory motion, so that each leg moves in a straight swing back relative to the body 9 as the latter moves forward, then hitches outwardly away from the wire, forwardly around the leg in position on the path and inwardly to engagement with and to a position resting on the path in advance of the other leg which was in position on the path. The mounting of the legs 10 and 11 is the same, although facing in opposite directions, so that the slots 19 are both on the inside and the openings 17 on the outside, thereby giving the legs 10 and 11 a similar movement and yet in different manners.

The body portion 9 is provided with any suitable head 20 such as a doll's head, so as to give a suitable appearance. Arms 21 and 22 are also provided extending outwardly from the body portion 9. These arms in order to give a pleasing or attractive appearance are represented as carrying flags 23 and 24. The flags, however, perform an important function of the device in that the lower portions of the staffs thereof are heavily weighted as at 25 and 26, so as to bring the center of gravity of the device as a whole quite low with respect to the tight wire or path 1 and in fact preferably below the same. The staffs of the flags may also incline inwardly toward a point below the

path 1, so as to bring the center of gravity in effect beneath and in line with the path 1. The flag staffs may be suitably braced if desired to the arms 21 and 22 by means of struts 27 and 28. The works of the manikin may be suitably concealed and the manikin may be clothed as by means of a parti-colored dress and cap after the manner of a clown.

We now come to the particular means whereby the force of gravity acts to cause the step by step movement of the manikin along the path 1. The legs 10 and 11 are connected by a link 29 which in effect is a lever and acts to advance first one leg and then the other. This link or lever 29 is shown in the form of a plate somewhat loosely connected to the leg 11 as by a pivot pin or the like 30 extending through an opening 31 in one end of the lever and is also connected in a similar manner to the leg 10 by means of a pivot pin 32 extending through an opening 33 in the plate 29.

In order to transmit the effect of the force of gravity on the lever 29 and thus alternately on the legs 10 and 11, there is provided a member 34 which extends through an opening 35 in the lever 29. This member 34 is connected to the body portion 9, so that the effect of the force of gravity as it pulls slightly in advance of the point or points of support of the manikin exerts its force on the lever 29 to alternately throw it, first in one direction and then the other and thereby throw each of the legs 10 and 11 alternately forward in advance of the other leg. The member 34 might be rigidly connected to the body portion 9, but in order to aid the effect and give a natural hitching motion to the device, is connected to the body portion 9 by means of a spring 36.

In order to further aid the nice operation of the device, the opening 35 in which the member 34 extends is shown in the form of a slot having the end portions 37 and 38 extending at an angle to each other. In the present embodiment also the angular portions 37 and 38 are shown as connected by straight reach 39, although this is not absolutely necessary, but adds to the effect of the device by delaying the swing of each leg until the member 34 passes corners 40 and 41, and thus gives a snap movement to the lever 29 and the attached parts.

It will thus be seen that the member 34 while obtaining its effect from the force of gravity, also obtains an added effect from the spring 36 so that it alternately swings the lever 29 first about the pin 30 as a fulcrum and then about the pin 32 as a fulcrum, advancing the legs 10 and 11 alternately. In order to add to the nicety of operation of the legs, the member 34 is bent as at 42 to form of the lower portion thereof a cam, which by its inclination, will tend to lift up each leg

to bring it properly in engagement with the path 1 as it comes to its foremost position.

In order to slightly retard the movement of the device in case it is walking too fast as when the wire 1 is placed at too great an inclination, the member 34 is located slightly in advance of the pivot shaft 12, so that it will come in engagement with the latter and prevent or at least retard the complete backward movement of each leg with respect to the body portion 9 until the other leg has reached a position in front of and clear of the leg moving backwardly relative to the body portion 9.

In order that the legs 10 and 11 may properly engage and cling to the wire 1, they are each provided with a foot 43, the sole of which is formed with a somewhat cylindrical surface 44 like the rim of a wheel, so that it will in effect roll on the wire or path 1 and there is further provided in each sole a groove 45 which may fit the wire 1 more or less closely. In Figs. 1 to 7, the groove 45 is shown as exactly fitting the wire 1 requiring the foot 10 to be placed accurately on the wire. In Fig. 8, is shown a modified form of foot in which there is a V groove 45 which will engage any size of wire and suit itself thereto so as to cling under all circumstances. It will be noted by reference to Fig. 5, that when both the feet 43 are in engagement with the wire 1 that they form in effect a continuous rolling surface having the same center.

In using the toy, the manikin is placed on the path 1 as in Fig. 1, with one foot slightly in the rear of the other, so that the effect of gravity will exert itself on the line extending between the two points of support of the two feet of the manikin. Under such a condition, the manikin will be in stable equilibrium and will remain stationary in perfect poise on the path 1. When it is desired to have the manikin advance along the path 1, it is merely necessary to press slightly on his back so as to move the center of gravity of the device as a whole slightly forward of the points of support. Under these circumstances, the force of gravity will tend to move the body portion 9 forward from the position shown in Figs. 1 and 6. In moving forward, the device as a whole will tend to rotate on the cylindrical surface of the soles of the feet 43 and more particularly upon the sole of the foot of the leg 10. As the body portion 9 moves forward under the pull of the mass of the body, the member 34 transmits the effect of the force of gravity to the lever 29, tending to rock the same about the pin 32 as a fulcrum. This action, however, is opposed by the foot of the leg 11 still clinging to the path or wire 1. As soon, however, as the body portion 9 has moved far enough forward under the pull of

when stable standing

gravity to have the leg 11 roll clear in a rearward direction of the path or wire 1 as by having the center of gravity move so far forward that no further weight will be resting on the rearmost leg 11, then as the leg 11 clears the path or wire 1, the member 34, due to the force of gravity and to the tension of the spring 36 which has been accumulating, will flip the lever 29 from the position shown in Fig. 3 to the position shown in Fig. 4. In doing this, the member 34 passes out of the angular portion 37 of the slot 35 through the ridge 41 and into the angular portion 38. The latter portion of the motion of the member 34 by virtue of the cam bend thereof will tend to lift the end of the lever 29 and thus lift the foot upon the leg 11 up until it comes into engagement and accurately seats itself with the groove 45 meshing with the path or wire 1. The device has now gained momentum so that it passes down the path 1 continuously. The leg 11 now is in advance of the leg 10 and as the leg 10 remains stationary and the body portion 9 passes forwardly relatively thereto, this leg 10 also arrives at a condition where it will leave the path or wire 1. Before this occurs, however, the member 34 will come into engagement with the shaft 12 especially if the manikin is traveling at any speed giving the leg 11 sufficient time to actually position itself on the wire 1 before the foot of the leg 10 will have time to leave the wire 1. This action gives a hitching motion to the movement of the manikin which is quite lifelike.

It will be noted by virtue of the universal connection of the legs 10 and 11 to the body portion 9 that they have a swinging movement in a plane somewhat conforming to the line of travel of the manikin and then an arcuate out-and-in movement to clear the leg in position on the path 1. This out-and-in movement is aided by the lever 29 acting as a thrust link to force the legs to alternately swing out and in in an arcuate path. After the leg 10 has reached a position such that it too leaves the path or wire 1, then the member 34 acts to swing the lever 29 about the pin 30 as a pivot from the position shown in Fig. 4 to the position shown in Fig. 3, the member 34 again snapping over to the opposite end of the slot 35. This action is continuous as long as there is an inclined path 1 along which the manikin 8 may travel, each foot alternating in its engagement with the path in advance of the other and leaving the wire after the weight is moved forward off the same and then hitching forward naturally again to a position in advance of the other foot.

While I have shown one embodiment of my invention, I do not wish to be limited to the specific details thereof, but desire to be

protected in various changes, alterations and modifications which may come within the scope of the appended claims.

Having thus described my invention, I claim as new and desire to secure by Letters Patent:

50 its statically stable

1. In combination with a path, of a manikin arranged to travel along said path, said manikin having a plurality of supporting points for engagement with said path and comprising a figure, means for lowering the center of gravity of the manikin to a point below the contact of the supporting points with said path, and positive means for transmitting the pull of the force of gravity as exerted on said manikin so as to advance said supporting points in alternation along said path.

2. A manikin comprising a body portion, a pair of legs, each universally connected to said body portion, means for alternately swinging said legs one directly in advance of the other, and means for preventing the contacting with each other of said legs in passing.

3. A manikin comprising a body portion, a pair of legs, each having a universal connection with said body portion so as to be capable of swinging in a variety of directions, and an intervening means from leg to leg for transmitting a gyratory movement to each of said legs so as to advance each leg in alternation the one past the other.

4. A manikin comprising a body portion, a pair of legs pivotally connected to said body portion, a gravity tensioned spring means intervening between said legs and acting to shift each alternately past the other so as to effect a walking movement.

5. A manikin comprising a body portion, a pair of legs for said body portion, a pivot on said body portion, and a member for each of said legs secured thereto, each of said members including a flange having a loose connection with said pivot, a flange having a slotted connection with said pivot so as to enable a universal movement of each leg relative to said body portion, and means for actuating said legs.

6. A manikin comprising a body portion, a pair of legs for said body portion, a pivot on said body portion, a member for each of said legs secured thereto, each of said members including a flange having a loose connection with said pivot and a flange having a slotted connection with said pivot so as to enable a universal movement of each leg relative to said body portion, and means for advancing said legs alternately the one beyond the other to effect a walking movement of said manikin.

7. A manikin comprising a body portion, a pair of legs pivotally connected to said body portion, a lever connecting said legs,

and means for engaging said lever to alternately rock said lever in opposite directions to swing said legs in opposite directions.

8. A manikin comprising a body portion, a pair of legs pivotally connected to said body portion, a lever connected to said legs, and a member for operating said lever to alternately advance said legs one past the other to effect a walking operation of said manikin.

9. A manikin comprising a body portion, a pair of legs pivotally connected to said body portion, a lever connected to said legs, and a member for operating said lever to alternately advance said legs one past the other to effect a walking operation of said manikin, said member changing its point of application of force necessary to shift said lever with respect to said leg at the swinging of each leg past the other.

10. A manikin comprising a body portion, a pair of legs pivoted to said body portion, a connecting member for utilizing the force of gravity due to the weight of said manikin to alternately advance said legs one past the other, and mechanical means for enabling the change in point of application of the force of gravity through said member.

11. A manikin comprising a body portion, a pair of legs pivotally connected to said body portion, a lever connected to said legs, and a member acting to shift said lever about a point of connection with each of said legs as a fulcrum in alternation so as to swing the opposite leg from a position in the rear to a position in front.

12. A manikin comprising a body portion, a pair of legs pivotally connected to said body portion, a lever connected to said legs, and a member acting to shift said lever about a point of connection with each of said legs as a fulcrum in alternation so as to swing the opposite leg from a position in the rear to a position in front, said member changing its point of application of the shifting force with each shift of said lever.

13. A manikin comprising a body portion, a pair of legs each pivotally connected to the body portion, and a member yieldingly mounted on said body portion arranged to apply the force of gravity due to the weight of the manikin as a whole in shifting said legs alternately past each other.

14. A manikin comprising a body portion, a pair of legs pivotally connected to said body portion, a lever pivotally connected to both of said legs, a member engaging said lever to alternately swing said lever and said legs in opposite directions, and a spring connecting said member with said body portion.

15. A manikin comprising a body portion, a pair of legs pivotally connected to said body portion, a lever pivotally connected to each of said legs, said lever having a slot therein, a member engaging in said slot to alternately shift said lever and said legs in opposite directions, and a spring connecting said member with said body portion.

10 16. A manikin comprising a body portion, a pair of legs each having a universal connection to said body portion, a lever pivotally connected to each of said legs, said lever having an angular slot therein, and a member connected to said body portion and extending into said slot so as to transmit the effect of the force of gravity due to the weight of said manikin as a whole to alternately swing said lever and said legs in opposite directions.

20 17. A manikin comprising a body portion, a pair of legs pivotally connected to said body portion, a lever pivotally connected at its ends to said legs and having a slot therein with two portions extending at an angle to each other, and a member

engaging in said slot to shift said lever and said legs back and forth, said member changing from one end of said slot to the other and back again during the back and forth shifting of said lever.

18. A manikin comprising a body portion, a pair of legs pivotally connected to said body portion, a lever pivotally connected at its ends to said legs, said lever having a slot therein with the end portions extending at an angle to each other and an intermediate reach connecting said angular portion, and a member connected to said body portion and extending into said slot to outwardly shift said lever and said legs back and forth, said member shifting from one end of said slot to the other and shifting said lever.

Signed at West Orange, in the county of Essex and State of New Jersey, this 6th day of March, 1914.

HARVEY ALLISON.

Witnesses:

A. M. KENNEDY,
CHAS. W. NORTON.