

Your Name: _____

ENGRD 202 Quiz 6

Section day & time: _____

April 18, 2003

TA name & section #: _____

- 11) (7 pts) A member with a rectangular cross section has a tensile force P applied at its end. It is anchored to a rigid bracket, made of the same material, via a bolt. The bracket slides easily in the gap. Find
- a) The bearing stress σ_b on the bracket from the bolt.
 - b) The average shear stress τ in the bolt on one side of the bracket.
 - c) Neglecting any stress concentrations, find the elongation δ in the member (length L) due to P .

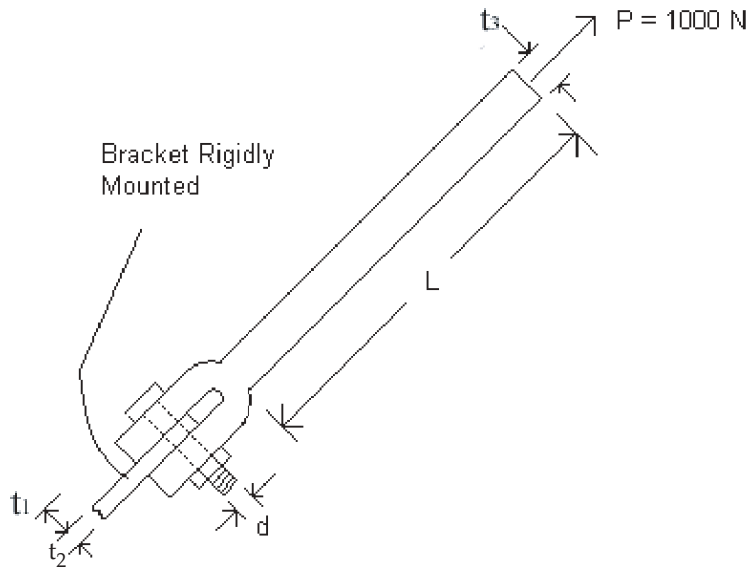

$L = 1 \text{ m}$, $d = 1 \text{ cm}$, $t_1 = 2 \text{ cm}$, $t_2 = \text{bracket thickness} = 1 \text{ cm}$, $t_3 = 3 \text{ cm}$.
The depth into page is 2 cm for the bracket and the other part.
 $E_{\text{bracket}} = E_{\text{member}} = 2.0 \times 10^6 \text{ Pa}$; $E_{\text{bolt}} = 1.0 \times 10^6 \text{ Pa}$

$\sigma_b =$
$\tau =$
$\delta =$

12) (10 pts) Three identical parallel posts are equally spaced. Two are connected to an initially-horizontal massless rigid beam. The weld at B' keeps the structure from collapsing. The third bar CC' misses being connected by the gap $\delta_g = 0.005$ inches which closes when that bar (and only that bar) is sufficiently heated. The rigid beam is then lifted by the expanding CC', and also tilts. After bar CC' is heated, what surface (what angle cut) in which vertical bar has the maximum shear stress? What is that shear stress τ ?

[You get full credit for a correct answer that has all letters or, alternatively (your choice) for one with all numbers and units. Make the usual small-strain, small-slope, linear elastic assumptions (no need to state them), and don't account for stress concentrations at the tops and bottoms of the bars.]

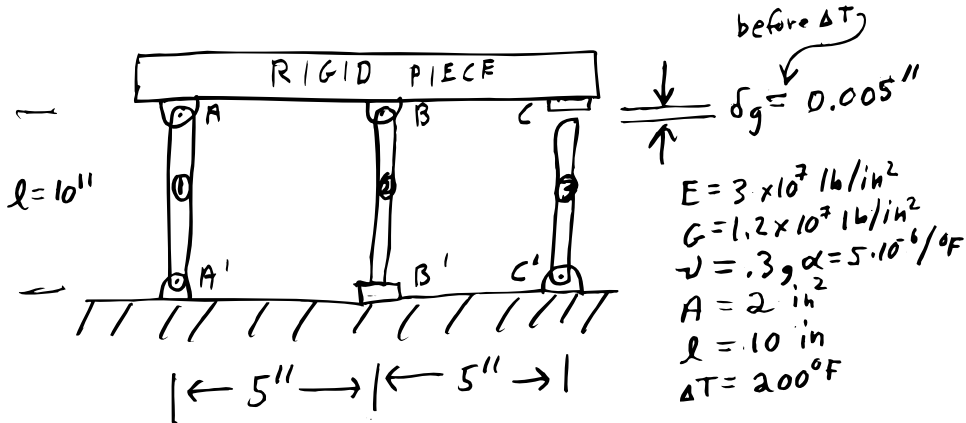

a) bar and surface
(describe or sketch clearly):

b) $\tau_{max} =$